



THE INNOVATOR IN
**SOUND & VIBRATION
 TECHNOLOGY**

+1.616.669.3028
 VibrationResearch.com
 vrsales@VibrationResearch.com

VR5800-BSR **Electrodynamic Shaker**

The system uses a larger shaker with the blower removed in a lower force output system. At 225F-lb the system offers the benefit of a larger shaker at a reduced price to give maximum performance at low and high frequencies. The added DC power supply generates a clean, quiet field and allows for tests to be run at incredibly low amplitude and sound levels. Dual meters display the system operating levels and complete shaker and user interlocks help protect the system from accidental abuse. Oil film slip table base systems are available for larger and heavier loads or loads with high centers of gravity.



VR5800-BSR SYSTEM SPECIFICATIONS

SINE FORCE	250F-lb pk
RANDOM FORCE	175F-lb rms
SHOCK FORCE	437F-lb pk
FREQUENCY RANGE	DC to 4,500Hz
MAX ACCELERATION	50g pk, bare table 25g pk, 5lb load 5.5g pk, 40lb load
MAX VELOCITY	85ips
MAX DISPLACEMENT	1" pk-pk
POWER REQUIREMENTS	5,200VA @ 100V*, 110V*, 200V, 208-230V 1Ø, 50/60Hz *request low line voltage operation details
COOLING	Natural convection
ARMATURE WEIGHT	5lbs
SUSPENSION STIFFNESS	250F-lb/in
DIMENSIONS	21"H x 14.5"W x 14"D
SHAKER WEIGHT	475lbs
STRAY MAGNETIC FIELD	Measured 3" above table: <10gauss Measured 2" from body: <15gauss
FUNDAMENTAL RESONANCE	3,000Hz to 4,000Hz load dependent 3,700Hz Typical

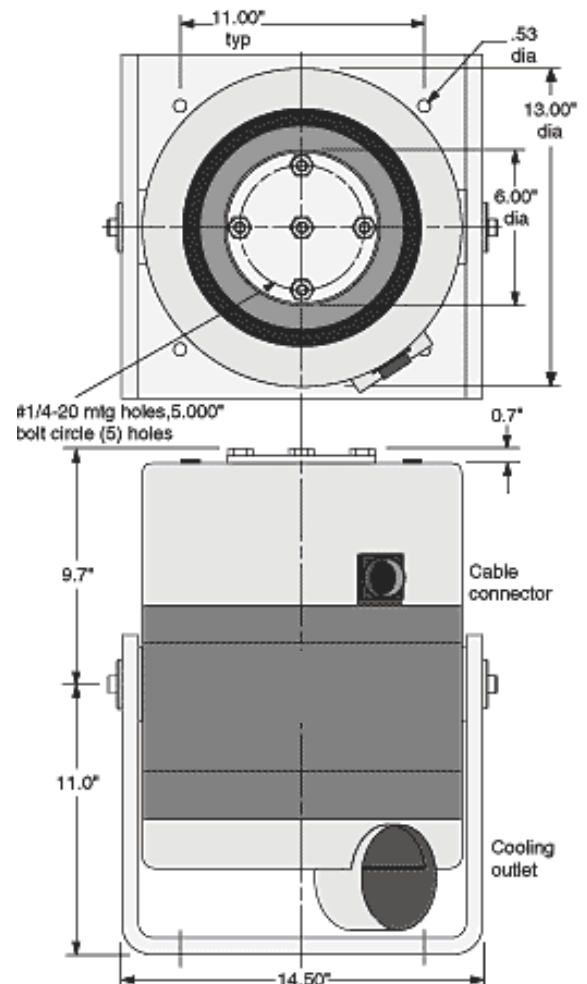

POWER AMPLIFIER

The amplifier houses a field and De-Gauss power supply specifically designed to drive the VR5800-BSR shaker. It is a class AB, air-cooled unit with a power output of 2,600VA, and is made up of three separate interconnected chassis. The flexible modular design allows this amplifier to be configured for use with other shakers.

The control panel features a low noise preamplifier, amplifier output voltage and current metering, adjustable output current limiting, and complete interlock circuitry. The power and field supply chassis houses input power transformers, power supply circuitry, the shaker interface, shaker cooling blower power source, and field cooling interlock circuitry.



AMPLIFIER PARAMETERS

Output voltage	65V rms
Output current	40A rms
Max. continuous dissipation	2,250W
Max voltage gain	40dB
Cooling	2-speed fan, automatic
Input impedance	10,000ohms
Meters	2 x Volts pk: 3-digit meters 2 x Amps RMS (Armature), DC (Field) 3-digit meter
Interlock circuit	External, user: N.O./N.C. switch or TTL
Dimensions	28"H x 21"W x 20"D
Weight	280lbs

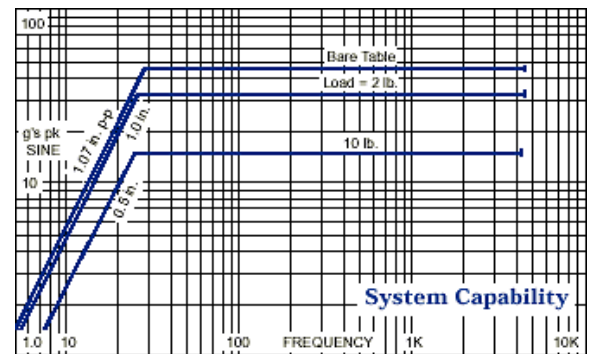

Lines not to scale

OPTIONS

- Vibration isolation mounts
- Metric inserts
- Pneumatic payload support
- Head plates & fixtures
- DuoBase horizontal/vertical table
- Vibration controllers
- Thermal chamber interface

THE INNOVATOR IN
**SOUND & VIBRATION
TECHNOLOGY**

+1.616.669.3028
VibrationResearch.com
vrsales@VibrationResearch.com

